

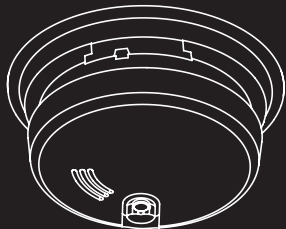

## Smoke Alarm User Guide



**Model: KF21** Optical 230V AC smoke alarm with 9V battery back-up

**Model: KF21R** Optical 230V AC smoke alarm with rechargeable battery back-up



LICENSE NO. KM 738872  
EN 14604:2005+AC:2008



2797-CPR-535595  
25  
EN 14604:2005+AC:2008



103.0001  
25  
EN 14604:2005+AC:2008  
AB:0086

## Thank You for Purchasing this Kidde product

Teach children how to respond to the alarm and that they should never play with the unit. This product was designed specifically for use in a residential environment.

**NOTE:** Please thoroughly read this user guide and save the document for future reference and to pass on to any subsequent owner.

**IMPORTANT:** Additional markings can be found on the back of the unit.

## ENVIRONMENTAL PROTECTION

Waste electrical products or equivalent should not be disposed of with household waste. Please recycle where facilities exist. Check with Local Authority or Supplier for recycling advice.

Model KF21R contains sealed in lithium batteries. Removal can be done only by qualified professionals in recycling points.

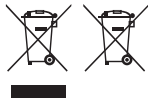

Product Support: 0800 917 0722

Please write down the below information and have this at hand when you call.

Model: \_\_\_\_\_

Date Code (on back): \_\_\_\_\_

Date of Purchase: \_\_\_\_\_

Where Purchased: \_\_\_\_\_

Date to Replace: \_\_\_\_\_

## CONTENTS OF THIS USER GUIDE

1. What to do When the Alarm Sounds.....	4
2. Introduction, Product Features and Specifications.....	6
3. Other Alarm Visual and Audible Indicators.....	7
4. Troubleshooting Guide.....	9
5. Limitations of Smoke Alarms.....	10
6. Recommended Locations for Smoke Alarms.....	11
7. Locations To Avoid.....	15
8. Installation Instructions Supply and Interconnect.....	16
9. Operation and Testing.....	25
10. Hush Control Feature.....	26
11. Battery Backup.....	27
12. Cleaning Your Alarm.....	29
13. Good Safety Habits.....	30
14. Service and warranty.....	31

## 1. What to do When the Alarm Sounds

### Smoke Alarm

Smoke alarm pattern is three long beeps, a 1.5 second pause, and three long beeps repeating. The red LED blinks in time with alarm pattern only on the alarm(s) that detected the hazard (initiating alarm).

- Alert small children in the home as well as anyone else that might have difficulty recognizing the importance of the alarm sounding or that might have difficulty leaving the area without help.
- Leave immediately by your escape plan. Every second counts, so don't waste time getting dressed or picking up valuables.
- While leaving, don't open any inside door without first feeling its surface. If hot, or if you see smoke seeping through cracks, don't open that door! Instead, use your alternate exit. If the inside of the door is cool, place your shoulder against it, open it slightly and be ready to slam it shut if heat and smoke rush in.
- If the escape route requires you to go through smoke, stay close to the floor where the air is cleaner. Crawl if necessary, and breathe shallowly through a cloth, wet if possible.
- Once outside, go to your selected meeting place and make sure everyone is there.
- Call the fire brigade from your mobile phone outside, or from your neighbour's home-not from yours!
- Don't return to your home until the fire officials say that it is all right to do so.

**NOTE:** See Section HUSH CONTROL FEATURE for nuisance alarm situations.

## Carbon Monoxide Alarm

**NOTE:** These smoke only models do not detect carbon monoxide (CO), but will receive and transmit a CO alarm signal from an interconnected CO or combination smoke / CO alarm.

**⚠ WARNING: CARBON MONOXIDE ALARM ACTIVATION INDICATES THE PRESENCE OF CARBON MONOXIDE (CO) AT HIGH CONCENTRATIONS WHICH CAN KILL YOU.**

Based on recommends from EN 50292, follow these steps if alarm sounds (4 loud audible pulses followed by a pause for 5 seconds):

1. Keep calm and open all doors and windows. Turn off all fuel-burning appliances if possible. Note: it is possible that outdoor conditions could influence domestic CO alarms (bad traffic pollution in cold weather, for example). In these circumstances, the level of indoor CO might actually increase when doors and windows are opened.
2. If the alarm continues to sound, even after being reset (where appropriate), then evacuate the premises, alerting other occupants to the risk. Leave doors and windows open. Do not re-enter the premises.
3. Get medical help for anyone suffering the effects of CO poisoning, and advise that CO inhalation is suspected.
4. Call Gas Emergency Services: 0800 111 999, or your local Gas Safe Registered Engineer:

**PHONE NUMBER:**

Never restart the source of the CO problem until it has been corrected. Never ignore the sound of the alarm! If the alarm is sounding, pressing the test/reset button will terminate the alarm. If the CO condition that caused the alert in the first place continues, the alarm will reactivate. If the unit alarms again, it is sensing high levels of CO which can quickly become a dangerous situation.

**⚠ CAUTION:** If there is any question as to the cause of an alarm it should be assumed that the alarm is due to dangerous levels of carbon monoxide and the dwelling should be evacuated.

**NOTE:** See Section Hush Control Feature for nuisance alarm situations, and also refer to the CO alarm user guide.

## 2. Introduction, Product Features and Specifications

### Introduction:

This alarm detects products of combustion using photoelectric technology and can be hardwire interconnected with Kidde and Firex smoke, heat and CO alarms, and other devices. Ten (10) years after the unit was installed, this unit will automatically alert you that it is time to replace the unit. This is called “End of Unit Life” mode. See Troubleshooting Guide. To help track the life of your alarm, write the installation date in the space provided on the alarm.

### Product Features and Specifications:

- Smoke Sensor: Photoelectric
- Hush Control to temporarily silence nuisance alarms
- Alarm Memory: Indicates that the alarm has previously detected a fire
- Temperature Operating Range: -10°C to 40°C
- Humidity Operating Range: up to 93% relative humidity (RH), non-condensing
- Storage and Transport Conditions: -20°C to +60°C, 5-95% RH (non-condensing)
- Audible Alarm: 85+ dB(A) at 3 m, 3.0 to 3.5 KHz pulsing alarm
- Power Supply: 230 VAC, 50 Hz, 0.05 A
- Battery Backup: Replaceable 9 V alkaline (KF21); Sealed-in rechargeable lithium batteries (KF21R)
- Interconnection: Hardwire interconnects with up to 24 other Kidde and Firex compatible alarms and devices

### 3. Other Alarm Visual and Audible Indicators

Condition	Visual Indications	Audible Indications	Action/Note
Normal (standby)	AC Power: Green LED on continuously. AC or Battery Power: Red LED blinks every 5 min	N/A	N/A
Device triggered by another Smoke, Heat alarm or accessory	Red LED flashes on initiating device only	3 long beeps, repeating	N/A
Device triggered by another CO alarm	Red LED flashes on initiating device only	4 quick beeps, repeating	A fire alarm will always take priority over a CO alarm
Test (button press for at least 5 seconds when no alarm condition is present)	Red LED blinks every second	3 long beeps, repeating whilst button is held	Perform this test every week to verify proper alarm operation. <b>NOTE:</b> this test will not take place when in Alarm Memory
Hush Mode	Red LED blinks every 10 seconds	After button push, Smoke alarm sound pattern stops	This feature is to be used only when a known alarm condition, such as smoke from cooking, activates the alarm

Condition	Visual Indications	Audible Indications	Action/Note
Smoke Alarm Memory (unit has experienced a smoke alarm event. This may have been while you were away.)	For the first 24 hours: Red LED flashes 3 times, every 40 seconds After 24 hours: no LED indication	For the first 24 hours: no audible indication After 24 hours, when the button is pressed, the unit chirps rapidly	A button press will clear alarm memory

**NOTE:** all timings are approximate.

## 4. Troubleshooting Guide

Trouble Condition	Visual Indications	Audible Indications	Action/Note
Low Battery	Red LED blinks every 40 seconds.	1 Chirp every 40 seconds.	KF21: Replace battery. KF21R: Unit must be under mains power for a minimum of 2 full days for sufficient charge. If the beeping persists after required charging period, return the unit for service (page 2). <b>NOTE:</b> the low battery signal can be hushed for 8 hours by pressing the test button.
End of Unit Life (unit in operation > 10-years)	N/A	3 Chirps every 40 seconds.	Replace unit as soon as possible.
Fault (unit in operation < 10-years)	N/A	3 Chirps every 40 seconds.	Remove power from unit and reconnect. If error continues replace as soon as possible.

## 5. Limitations of Smoke Alarms

### **⚠ WARNING: please read carefully and thoroughly.**

Life safety from fire in residential occupancies is based primarily on early notification to occupants of the need to escape, followed by the appropriate egress actions by those occupants.

- Fire warning systems for dwelling units are capable of protecting about half of the occupants in potentially fatal fires.

An alarm may not be effective in some situations, such as during incendiary fires where the fire grows so rapidly that an occupant's egress is blocked even with properly located alarms, or when victims are intimate with the fire (for example, when a person's clothes catch fire while cooking), too old or young, or physically or mentally impaired such that they cannot escape even when warned early enough that escape should be possible. For these people, additional strategies such as protection-in-place or assisted escape or rescue are necessary.

- There are situations where a smoke alarm may not be effective to protect against fire. For instance:

- a) smoking in bed

- b) leaving children home alone

- c) cleaning with flammable liquids, such as petrol

- A battery powered alarm must have a battery of the specified type, in good condition and installed properly.

- Smoke alarms must be tested regularly to make sure the battery and the alarm circuits are in good operating condition.

- Smoke alarms cannot provide an alarm if smoke does not reach the alarm. Therefore, smoke alarms may not sense fires starting in chimneys, walls, on roofs, on the other side of a closed door or on a different floor.

- If the alarm is located outside the bedroom or on a different floor, it may not wake up a sound sleeper.

- The use of alcohol or drugs may also impair one's ability to hear the smoke alarm. For maximum protection, a smoke alarm should be installed in each sleeping area on every level of a home.

- Although smoke alarms can help save lives by providing an early warning of a fire, they are not a substitute for an insurance policy. Home owners and renters should have adequate insurance to protect their lives and property.

**This alarm is not intended to alert hearing impaired individuals.**

## 6. Recommended Locations for Smoke Alarms

**NOTE:** According to BS 5839-6, for optimal fire protection: “The greatest benefit to life safety is given by a full-coverage system. Such a system will give the earliest practicable warning of fire to occupants, wherever ignition occurs.”

- Locate the first alarm in the immediate area of the bedrooms. Try to monitor the escape routes and rooms opening into escape routes as the bedrooms are usually farthest from the exit.
- If more than one sleeping area exists, locate additional alarms near each sleeping area. No bedroom door should be further than 3 m from the nearest alarm.
- Locate additional alarms between every bedroom and every other room in the dwelling (for example, an office, library or lounge), other than a toilet, bathroom or shower room.
- Locate additional alarms to monitor any stairway as stairways act like chimneys for smoke and heat.
- Locate at least one alarm on every floor level, including finished lofts. Locate an alarm between each staircase and every room, other than a toilet, bathroom or shower room.
- Locate an alarm in every bedroom.
- Locate an alarm in every room where electrical appliances are operated (i.e. portable heaters or humidifiers).
- Locate an alarm in every room where someone sleeps with the door closed. The closed door may prevent an alarm not located in that room from waking the sleeper.
- Locate one alarm in each principal habitable room.
- If a habitable room is an inner room with no doors or windows through which escape is possible, locate one alarm in the room used to access that inner room.
- In hallways, corridors, or rooms exceeding 7.5 m in length, no point within the hallway, corridor, or room should exceed 7.5 m from the nearest alarm.

- Smoke, heat, and combustion products rise to the ceiling and spread horizontally. Mounting the smoke alarm on the ceiling in the center of the room places it closest to all points in the room. Ceiling mounting is preferred in ordinary residential construction.
- When mounting an alarm on the ceiling, locate it at a minimum of 300 mm from the side wall or light fitting. **(Figure 6-A)**
- Where structural beams create an obstacle to flow of smoke across a ceiling: If the beam is less than 600 mm in depth, install an alarm on the underside of the beam. Otherwise, install an alarm both sides of the beam, but no closer than twice the depth of the beam, or 500 mm, whichever is less.
- When mounting the alarm on the wall, use an inside wall with the top edge of the alarm at a minimum of 150 mm below the ceiling, and the bottom edge of the alarm within 300 mm below the ceiling. **(Figure 6-A)**  
The bottom of the alarm should also be above the level of any door opening.
- Install alarms in positions that are reasonably accessible for maintenance.
- Install Smoke Alarms on sloped, peaked or cathedral ceilings within 600 mm of the highest point (measured vertically). **(Figure 6-C)**
- Install smoke alarms on the ceiling of tray-shaped ceilings, or within 300 mm of the ceiling. **(Figure 6-D)**

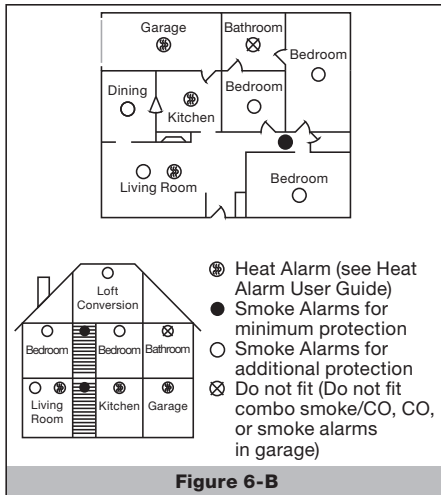
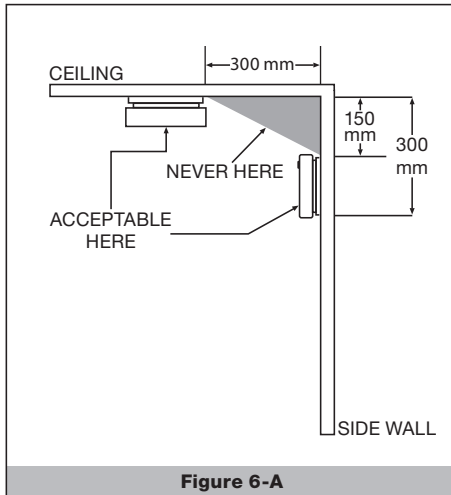

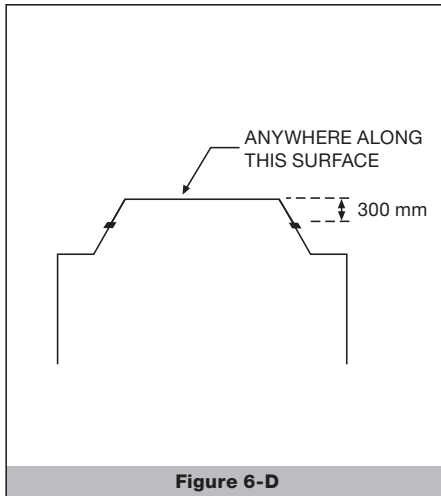
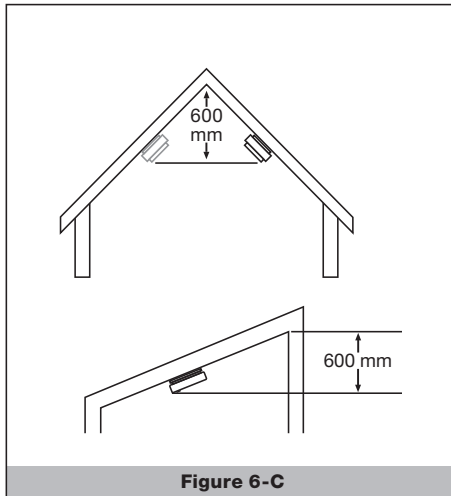

## 7. Locations To Avoid

- In the garage. Products of combustion are present when you start your motor vehicle.
- Do not install smoke alarms on the walls if the room or hallway exceeds 10 m in both length and breadth, or exceeds an area of 50 m<sup>2</sup>.
- Do not install alarms adjacent to, or directly above, heaters or air-conditioning vents.
- In very humid areas (above 90% RH, non-condensing), such as bathrooms and shower rooms. Do not install directly above a sink, or near dishwashers or washing machines. Moisture or steam can cause nuisance alarms.
- Normal cooking may cause nuisance alarms. If a kitchen alarm is desired, it should be an interconnected heat alarm.
- Do not install within 2 m of heating or cooking appliances, measured horizontally.
- Do not install outside of the dimensional guidelines given in **Figures 6-A, 6-C, and 6-D**.
- In an area where the temperature may fall below -10°C or rise above 40°C such as garages and unfinished attics.
- Do not install smoke alarms in dusty areas. Dust particles may cause nuisance alarm or failure to alarm.
- In insect-infested areas.
- Within 300 mm of a light fitting, as electronic “noise” generated by the electronics may cause nuisance alarms.
- Do not install in an enclosed space (cupboard) or where the ventilation openings in the unit could be impeded by items such as newspapers, table-cloths, furniture, curtains, etc.
- Do not install next to a door, window, extractor fan, flue, chimney, or any other area where high air flow may occur or the unit may be directly exposed to weather.
- Do not install in locations that are difficult or dangerous to reach for testing or maintenance.
- Do not install DC (battery only) alarms on top of AC electrical junction boxes.



**WARNING: To reduce the risk of fire or electric shock, do not expose this product to rain or moisture.**

## 8. Installation Instructions – Supply and Interconnect

**NOTE:** A dust cover has been installed on the alarm. Keep the dust cover on until all construction has been completed for at least 24 hours (plastering, painting, varnishing, etc). Retain the dust cover and re-install it to protect the alarm during future construction projects. Construction dust and chemicals can cause contamination and false alarms.

**⚠ WARNING: DUST COVER MUST BE REMOVED FOR ALARM TO OPERATE.**

### Wiring Requirements

- This alarm together with any associated supply and interconnect wiring is designed for installation by a qualified electrician in accordance with BS 7671 and any prevailing local wiring regulations and in regard to relevant building regulations and codes of practice. In addition, the resistance of the interconnect wiring shall be a maximum of 10 ohms.
- An appropriate all-pole disconnection device shall be provided as part of the building installation.
- The maximum wire run distance between the first and last unit in a hardwired interconnected system is 300 m.
- When alarms are hardwire interconnected, all interconnected units must be powered from a single circuit.
- This alarm must be powered by a constant 230 VAC, 50Hz supply that is not controlled by any form of switch.
- This device is not rated as waterproof and must not be exposed to dripping or splashing.
- This alarm interconnects with up to 24 other devices (of which 18 can be initiating) including smoke, CO and heat alarms.
- The following Kidde and Firex smoke, heat and CO models can be hardwire interconnected: KF21, KF21R, KF31, KF31R, KF20, KF20R, KF30, KF30R, 2SFW, 2SFWR, 3SFW, 3SFWR, 4MCO ,4MDCO, K4MCO. Contact Kidde to confirm compatibility with other models.
- This alarm is not designed to be interconnected with other manufacturer's products, unless otherwise specified.

**⚠ WARNING:** Turn off the main power to the circuit before wiring the alarm.

**⚠ WARNING:** The alarm cannot be operated from power derived from a square wave modified square wave or modified sine wave, inverter. These types of inverters are sometimes used to supply power to the structure in off grid installations, such as solar or wind derived power sources. These power sources produce high peak voltages that will damage the alarm.

**⚠ WARNING:** An appropriate all-pole disconnection device shall be provided as part of the building installation.

**⚠ WARNING:** We recommend these alarms are supplied on their own dedicated final circuit protected by an appropriate rated fuse / circuit breaker. They can be supplied from other final circuits, but please be aware that if these other circuits supply high power loads this could result in unwanted alarming.

**⚠ CAUTION:** The alarm(s) must be disconnected before high voltage insulation testing the wiring circuit. Failure to do so could damage the alarm.

**⚠ CAUTION:** This unit is sealed. The cover is not removable.

## INTERCONNECTING ALARMS

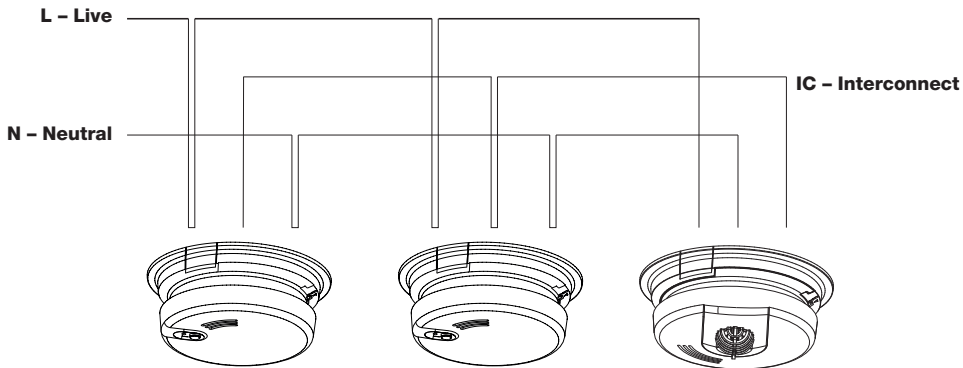

**Figure 8-A**

**NOTE:** Use cable type 6242Y / 6243Y or equivalent in accordance with local regulations.

**⚠ WARNING:** Disconnect the mains supply to the circuit before wiring.

Kidde alarms are not designed, agency tested or certified for recessed mounting and should not be installed in this manner. Recessed mounting impedes smoke entry into the smoke chamber, which may prevent the alarm from sounding in a timely manner. This could endanger the lives of occupants in the residence. Kidde alarms are designed, tested and certified for wall (if applicable) and ceiling surface mount only. Without agency research, we have no fire test data to support that alarms will perform as required when installed in a recessed manner. Accordingly, we do not recommend, approve or advise mounting Kidde alarms in recessed configurations.

- Determine if the supply cable will enter the alarm base via the rear or side entry.
- For side entry, the baseplate will facilitate connection to 25 mm x 16 mm surface trunking as shown in **Figure 8-C**. Carefully cut out one or both marked sections on the baseplate as required.
- Affix the alarm mounting plate to the ceiling or wall using suitable screws. Ceiling installation should be used wherever possible.
- Remove the terminal cover, **Figure 8-B**.
- Route the mains supply/interconnect cable into the Quick-Fit installation base via the rear or side cable entry as required.
- Strip the wires to the required length and connect to the correct screw terminals.

Live (L)

Neutral (N)

Interconnect (IC)

**NOTE:** This is a Class II device and does not to be earthed.

However, a terminal is provided so that any circuit protective conductor (CPC) can be terminated safely.

**NOTE:** Do not use a CPC for the interconnect conductor.

- Replace the terminal cover.

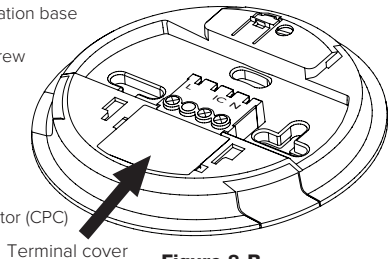

**Figure 8-B**

- Remove pull tab to activate battery backup and provide power to the unit in the event of mains power loss (Model KF21 only), **Figure 8-D**. Smoke alarm may beep briefly when battery is activated.
- Remove protective cap from connector on alarm head and discard cap, **Figure 8-E**.
- Slide the alarm head onto the base until it clicks into place **Figures 8-F, 8-G and 8-H**.
- Turn on main power.
- Test the alarm. See section "Operation and Testing".

**▲ WARNING: Failure to properly install and activate this alarm will prevent proper operation and will prevent its response to smoke hazards.**

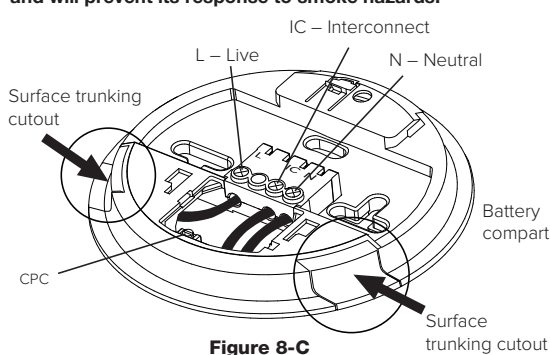

**Figure 8-C**

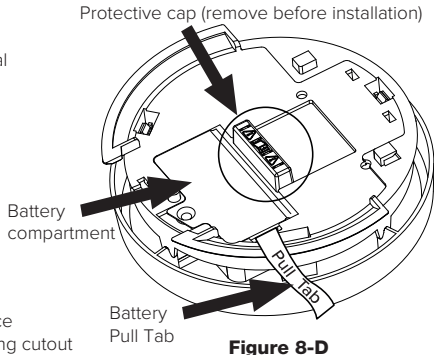

**Figure 8-D**

## Step-by-step installation of alarm on the Quick-fit base

**Step. 1** Pull protective cap up to remove and discard cap. Remove battery pull tab (Model KF21 only).

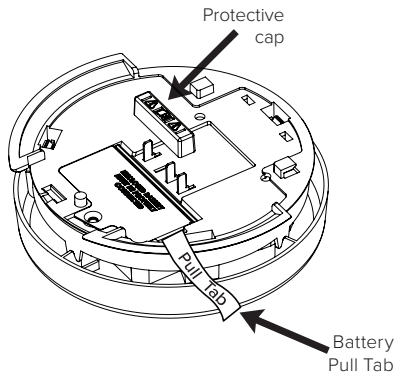

**Figure 8-E**

**Step. 2** Align the lugs on the alarm with the notches on the base.

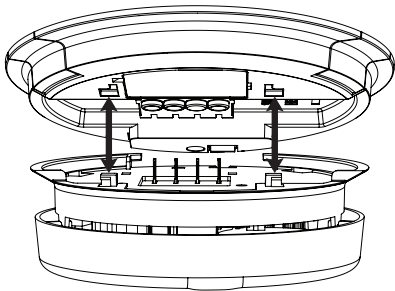

**Figure 8-F**

## Step-by-step installation of alarm on the Quick-fit base

**Step. 3** Apply upward pressure and slide the alarm into the Quick-fit base rail in the direction of the arrow below.

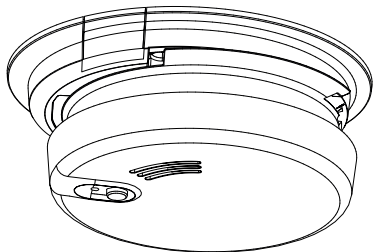

Slide in direction  
of arrow

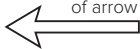

**Figure 8-G**

**Step. 4** Alarm clicks into place.

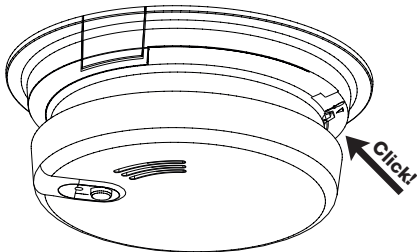

**Figure 8-H**

## Step-by-step removal of the alarm from the Quick-fit base

**Step. 1** Find the marked spot and insert flat bladed screwdriver to enable removal of the alarm.

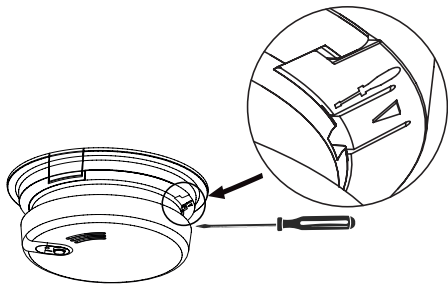

**Figure 8-I**

**Step. 2** Carefully slide the alarm in the direction of the arrow below.

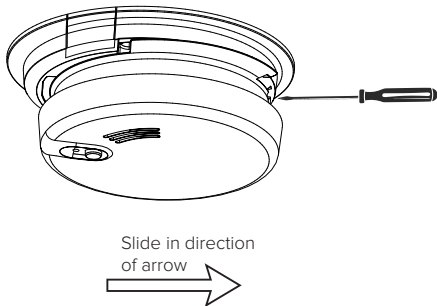

**Figure 8-J**

## Step-by-step removal of the alarm from the Quick-fit base

**Step. 3** Pull the alarm down to completely remove from the Quick-fit base.

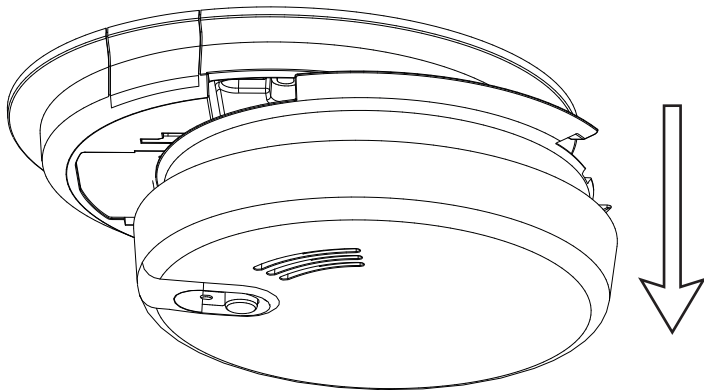

**Figure 8-K**

## 9. Operation and Testing

**Operation:** The smoke alarm is operating once AC mains wiring is connected, a fresh battery is installed (replaceable battery models), and testing is complete. When products of combustion are sensed, the unit sounds a loud 85 dB pulsating alarm until the air is cleared. See section: What To Do When the Alarm Sounds.

**Testing:** Test by pushing the button on the cover and holding it down for a minimum of 5 seconds. This will sound the alarm if the electronic circuitry, horn and battery are working. If no alarm sounds, the unit has a defective battery or other failure.

**NOTE:** If smoke alarms are interconnected, all smoke alarms should sound an alarm within three seconds after any test button is pushed and the tested smoke alarm sounds.

**Test the alarm weekly to ensure proper operation.**

**Never use an open flame or combustible materials to test your alarm, you could damage the alarm or ignite nearby materials and start a fire.**

**NOTE:** If at any time your alarm fails to operate correctly (erratic or low sound, for example), contact Kidde Safety (see page 2 for contact details).

## 10. Hush Control Feature

### Smoke Nuisance

The Hush feature is extremely useful in a kitchen area or other areas prone to nuisance alarms. The Hush feature has the capability of temporarily desensitizing the smoke alarm circuit for about 9 minutes. This feature should only be used when a known alarm condition, such as smoke from cooking, activates the alarm. If the alarm does sound, check for fires first. If a fire is discovered, get out and call the fire department. If no fire is present, check to see if one of the reasons listed in Locations to Avoid may have caused the alarm. The smoke alarm is desensitized by pushing the button on the smoke alarm cover. The alarm will silence immediately for approximately 9 minutes and the red LED will blink every 10 seconds. This indicates that the alarm is in a temporarily desensitized condition. The smoke alarm will automatically reset after approximately 9 minutes. If after this period particles of combustion are still present, the alarm will sound again. The Hush feature can be used repeatedly until the air has been cleared of the condition causing the alarm.

**If there is any question as to the cause of an alarm, it should be assumed that the alarm is due to an actual fire and the dwelling should be evacuated immediately.**

**⚠ CAUTION: Before using the alarm smart hush feature. Identify the source of the smoke and be certain a safe condition exists.**

### Carbon Monoxide (CO) Nuisance

**NOTE:** These smoke only models do not detect CO, but will receive and transmit a CO alarm signal from an interconnected CO or combination smoke/CO alarm. Pushing the button on a smoke only model when it is transmitting an interconnected CO alarm signal will do nothing.

**⚠ WARNING: IT IS IMPOSSIBLE TO DETERMINE THE SOURCE OF A CO ALARM USING SIGHT OR SMELL. ALWAYS CONSIDER A CO ALARM EVENT AS DANGEROUS.**

## 11. Battery Backup

### Replaceable battery model

**⚠ WARNING: Alarm will not attach to Quick-Fit installation base unless battery is installed.**

**Removal of battery will render the unit inoperative.**

To replace the battery, remove the alarm from the Quick-Fit base **(Figures 8-I, 8-J, and 8-K)** and open the battery cover on the alarm. **(Figure 8-D)**

A fresh battery should last for one year under normal operating conditions.

### Low Battery

Model KF21 has a low battery monitor circuit which will cause the alarm to “chirp” and flash the red LED for a minimum of 30 days when the battery gets low (see Troubleshooting Guide). Replace the battery when this condition occurs.

**Use only the following 9 volt batteries for smoke alarm replacement:**

Alkaline Type: ENERGIZER 522, DURACELL MN1604, MX1604

**NOTE: Do not use lithium batteries in this unit.**

**NOTE: Weekly testing is required.**

**⚠ WARNING! Use only the batteries specified. Use of different batteries may have a detrimental effect on the smoke alarm.**

## Rechargeable Battery Model

**NOTE:** Rechargeable lithium batteries are permanently mounted and sealed in the tamper-proof housing. These cells are designed to last the useful life of the smoke alarm.

## Low Battery

Model KF21R has a low battery monitor circuit which will cause the alarm to “chirp” and flash the red LED when the battery gets low (see Troubleshooting Guide). If this condition occurs, confirm that AC power is connected as this is required to charge the battery (can take up to 2 days to charge). The alarm should be replaced if chirping persists after mains power is connected for a minimum of 2 days. Note that the battery is not replaceable.

**NOTE: Constant exposures to extreme temperatures or humidity may reduce battery life.**

## 12. Cleaning Your Alarm

### Your Alarm Should be Cleaned at Least Once a Year

You can clean the interior of your alarm (sensing chamber) by using compressed air or a vacuum cleaner hose and blowing or vacuuming through the openings around the perimeter of the alarm. The outside of the alarm can be wiped with a damp cloth. Use only water to dampen the cloth, use of detergents or cleaners could damage the alarm.

- Never use detergent or other solvents to clean the unit.
- Avoid spraying air freshener, hair spray, or other aerosols near the alarm.
- Do not paint the unit. Paint will seal the vents and interfere with the sensor's ability to detect smoke.
- Never attempt to disassemble the unit to clean inside. This action will void your warranty.



**WARNING: Reinstall the Alarm as soon as possible to ensure continuous protection.**

## 13. Good Safety Habits

### Develop and Practice a Plan of Escape

Prepare and practice a home escape plan twice a year, including drills at night. Know two ways out of every room (door & window) and identify a meeting place outside the home where everyone will gather once they have exited the residence. When two people have reached the meeting place, one should leave to call 999 or 112 while the second person stays to account for additional family members. Establish a rule that once you're out, you never re-enter under any circumstance!

- Make a floor plan indicating all doors and windows and at least two (2) escape routes from each room. Second story windows may need a rope or chain ladder.
- Have a family meeting and discuss your escape plan, showing everyone what to do in case of fire and where to meet after they leave the house.
- Ensure that small children hear the alarm and wake when it sounds. They must wake up in order to execute the escape plan. Practice allows all occupants to test your plan before an emergency. You may not be able to reach your children. It is important they know what to do.
- Familiarize everyone with the sounds of the smoke alarm and train them to leave your home when they hear it.
- Current studies have shown smoke alarms may not awaken all sleeping individuals, and that it is the responsibility of individuals in the household that are capable of assisting others to provide assistance to those who may not be awakened by the alarm sound, or to those who may be incapable of safely evacuating the area unassisted.

### Smoke Detection – Are More Alarms Desirable?

The required number of smoke alarms might not provide reliable early warning protection for those areas separated by a door from the areas protected by the required smoke alarms. For this reason, it is recommended that the house holder consider the use of additional smoke alarms for those areas for increased protection. The additional areas include the basement, bedrooms, dining room, utility room, and hallways not protected by the required smoke alarms. The installation of the smoke alarms in the kitchen, or garage is normally not recommended, as these locations occasionally experience conditions that can result in improper operation.

## 14. Service and warranty

### TEN YEAR LIMITED WARRANTY

KIDDE warrants to the original purchaser that the enclosed alarm (but not the battery on replaceable battery models) will be free from defects in material and workmanship or design under normal use and service for a period of ten years from the date of purchase. The obligation of KIDDE under this warranty is limited to repairing or replacing the alarm or any part which we find to be defective in material, workmanship or design (part replacement only, no installation), free of charge to the customer, upon presentation of the proof purchase.

This warranty shall not apply to the alarm if it has been damaged, modified, abused or altered after the date of purchase or if it fails to operate due to improper maintenance or inadequate A.C. or D.C. electrical power.

THE LIABILITY OF KIDDE OR ANY OF ITS PARENT OR SUBSIDIARY CORPORATIONS ARISING FROM THE SALE OF THIS ALARM OR UNDER THE TERMS OF THIS LIMITED WARRANTY SHALL NOT IN ANY CASE EXCEED THE COST OF REPLACEMENT OF ALARM AND, IN NO CASE, SHALL KIDDE OR ANY OF ITS PARENT OR SUBSIDIARY CORPORATIONS BE LIABLE FOR CONSEQUENTIAL LOSS OR DAMAGES RESULTING FROM THE FAILURE OF THE ALARM OR FOR BREACH OF THIS OR ANY OTHER WARRANTY, EXPRESS OR IMPLIED, EVEN IF THE LOSS OR DAMAGE IS CAUSED BY THE COMPANY'S NEGLIGENCE OR FAULT.

This warranty does not affect your statutory rights. To make a claim:

If a defect in the product appears within the time frame stated, you are entitled to submit a warranty claim by returning your product to Kidde. For return address please contact KIDDE on the telephone numbers provided on page 2 of this User Guide or via the latest contact details given on our website.

Before shipping the product, please remove the batteries from the battery compartment, or follow the steps in Permanently Disable Alarm / Discharge Battery section, depending your model type. When returning the product, please ensure it is properly packaged so that no damage occurs during transit. Any postage and packaging expenses required to return the product to KIDDE or its authorised agents will be at your cost. Please provide the original or a copy of the proof of purchase. Also, please make sure you have included an explanation of the problem.



©2025 Kidde All Rights Reserved.  
QUESTIONS OR FOR MORE INFORMATION

Manufactured By:  
Walter Kidde Portable Equipment  
1016 Corporate Park Drive, Mebane, NC 27302, USA  
[www.kiddesafetyeurope.co.uk](http://www.kiddesafetyeurope.co.uk)  
Made in China

EU Authorised Representative  
KGS Fire & Security B.V.  
Kelvinstraat 7, 6003 DH Weert, NL

UK Contact  
Kidde Safety Europe Ltd  
[www.kiddesafetyeurope.co.uk](http://www.kiddesafetyeurope.co.uk)

## Regulation (EU) NO.305/2011 CPR supplementary CE marking information



Identification of the Certification Body: 2797

Manufacturer: Walter Kidde Portable Equipment  
1016 Corporate Park Drive  
Mebane, NC 27302, USA

Last two digits of year CE mark was first placed: 25

Declaration of Performance (DoP) Number: 2797-CPR-535595

EN standard: EN 14604:2005+AC:2008

Unique identification of product type: See the product label for the product documentation part number and revision

Intended use: Fire safety (residential buildings, apartments and rooms with similar purposes)

Essential characteristics: see DoP performance table

Get this document in your language from:

[www.kiddesafetyeurope.co.uk](http://www.kiddesafetyeurope.co.uk)